

# AW Positive Displacement Flow Meters

## Installation & Operating Guide

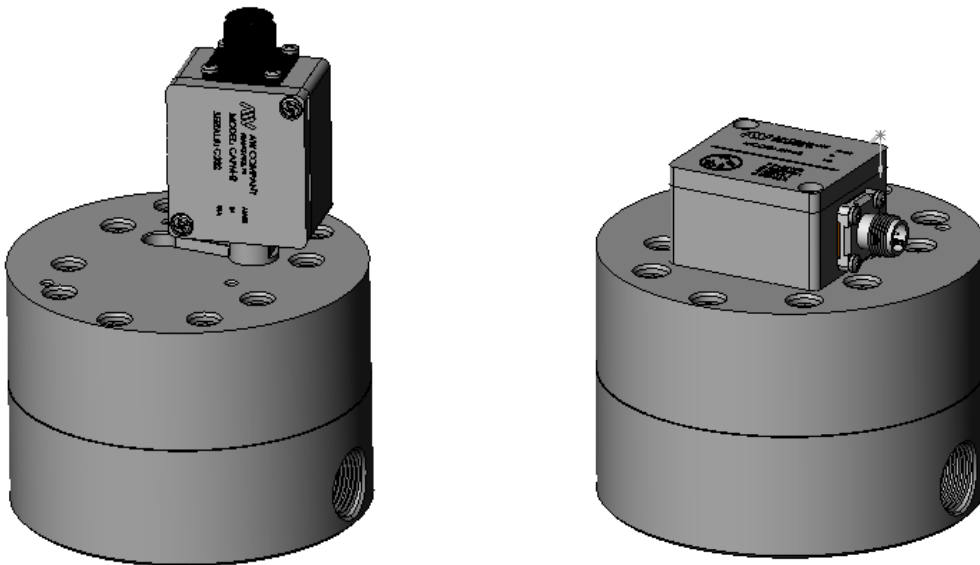

### General Description:

The AW Flow Meter's positive displacement gear flow meters are similar in design to the gear pump. The principle of operation is reversed; instead of the gears driving the medium, the medium drives the gears. A non-intrusive hall-effect sensor detects the movement of the gear and as each gear tooth passes the sensor a square wave pulse is produced and a discrete volume of liquid is measured. The resulting pulse train is proportional to the actual flow rate and provides a highly accurate representation of the fluid flow. All meters are designed with highly wear resistant moving parts to provide exceptionally long service life.

### **Filtration:**

Depends upon model

### **Fluid Compatibility:**

The materials of construction are stainless steel or high strength aluminum housing, stainless steel gears and either tungsten carbide or stainless steel bearings (depending upon the model). The fluids should be compatible with these materials.

## Installation Instructions

The **preferred flow direction** is etched or marked by an arrow on the meter as this is the flow direction in which the meter was calibrated however, the flow meters have bi-directional flow capabilities. Damage will not occur from reverse flow but the meter will count reverse flow as forward flow so to prevent this possibility, an in-line check valve may be a consideration.

The **preferred orientation** is to mount the meter vertically although horizontal mounting is acceptable if conditions deter vertical orientation. There is no need for straight run piping upstream or downstream of the flow meter.

**Install the meter upstream from control valves and fluid regulators if possible** - see Fig.1.

Back pressure from control valving is beneficial for stable running.

**Eliminate all dirt, debris and metal shavings from the piping** as the liquid must be free from any particles larger than allowed by the manufacturer's specifications. Any recommended filtration should be installed before operation as potential plugging most often occurs at startup.

**If possible install a bypass** around the meter and flush existing piping with the appropriate solvent before first use - see Fig.1.

**Review the pickup instructional guide prior to installation.** Locate the pickup & wiring away from A/C motors, actuators, heaters, relays etc. Use only shielded cable and do not take power from the same circuits as other devices. Ensure clean power supplies which utilize a true earth ground. Intrinsic Safety Barriers must be installed if the circuit is intended to be intrinsically safe.

**The pickup sensor should only be installed hand tight...** do not use wrenches or channel locks. Over tightening may cause a dimple to protrude into the meter chamber beneath the pickup and interfere with the free gear rotation.

Figure 1

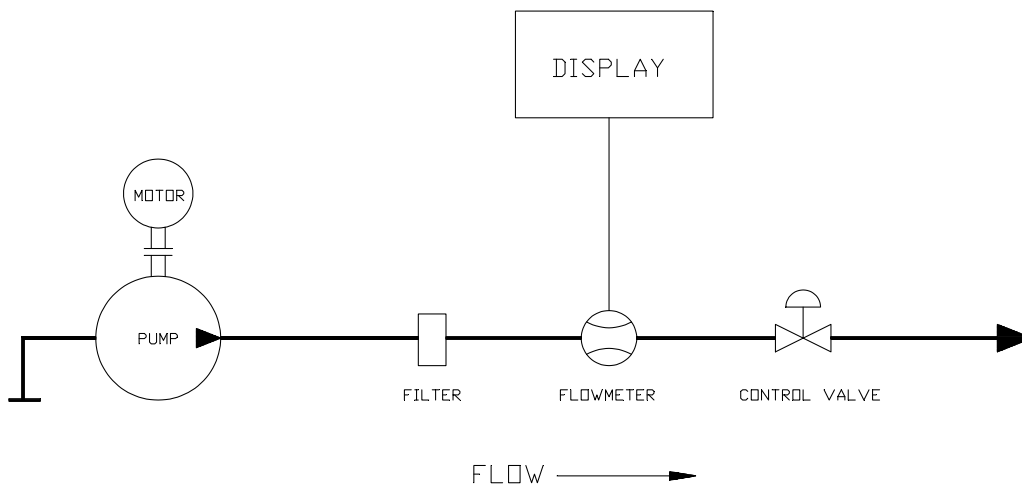

**Maintenance Guides** are provided with the meter and are also available from the factory — these should always be reviewed by personnel prior to attempting any maintenance work.

The overwhelming majority of down time & repairs are the result of breakages due to improper maintenance actions, lack of training or rough handling.

**Never run the meter dry or spin with air only** - Gear flow meters are precision engineered flow devices - they should always be maintained in a clean, lubricated condition with the internals wet at all times. Air and water should not be allowed in contact with the internal parts except in short (1-2 second) cycles as part of an automated flush.

**Don't use water for flow testing** - the viscosity of water is too low to produce accurate results unless the flow rate is elevated and the internals would then have to be dried and lubricated to avoid corrosion or scaling. Using a fluid with a viscosity of approximately 30 cSt such as mineral oil or thinned glycerin is recommended if calibration of the system is necessary - the preferred calibration fluid would be the actual fluid to be metered.

**Don't ramp-up flow to a full flow condition instantaneously** - Gear flow meters are rugged yet precise instruments which will respond almost instantaneously to changes in fluid flow. Normal pulsating flows will not damage the meter and will merely cause the output to be unsteady however, if flow is repeatedly cycled from zero to full flow instantaneously, fluid shock forces may be significant and may produce premature damage or wear over time. To avoid damage to the system ramp-up to max flow over a few seconds rather than instantaneously & do not inject high flow speeds into an empty meter.

**Filtration** is recommended to prevent contaminants from entering the meter. **Should the meter become plugged**, a reduced flow may still be observed from the outlet as fluid pressure will squeeze fluid through the meter — visual flow does not necessarily mean that the meter's gears are turning. If plugging is caused by contaminants then filtering should be installed...if plugging is repeatedly caused by particle build up then review the cleaning and maintenance procedures in the following section. Because of the vast differences in fluid types and in-plant procedures there may be some trial and error involved in determining the ideal flushing or cleaning regimen.

**A calibration factor (K Factor)** is established at the factory on a preferred calibrating fluid - this number is usually accurate for a wide variety of fluids and should not usually be changed — it is provided with the meter either on a Calibration Data Sheet or on a tag attached to the meter. Should it be lost, a copy can be obtained from the factory. A calibration verification procedure is detailed later in this document.

**Storage** - when the flow meter is idle or stored for any extended period of time the internals should be thoroughly cleaned with the appropriate solvent, lubricated with a light oil and the ports capped or plugged to prevent drying

## Flow Meter Guidelines for Paint Operations

**Before installing, operating or attempting maintenance on a flow meter read the appropriate Maintenance Guide. As with any precision engineered device, the equipment should always be operated and maintained in accordance with the manufacturer's instructions.**

Flow Meters are designed to flow liquids which assist in cooling and lubrication. Meters should always be closed to air except when air is part of an automated purge cycle — in this case the air segments are typically under 1-2 seconds and are interspersed with lubrication solvent to achieve a scrubbing effect — the air segments are short enough that the meter doesn't dry out — see Fig 2.

**Do not dry paint lines using only pressurized air as this will lead to premature wear.**

At the end of a shift or overnight it is **strongly recommended that cleaning solvent or DI water with appropriate cutting agent be left in the meter, under pressure, to soak.** This helps keep unflushed residual paint from drying and helps subsequent start-ups. Opening a meter after a flush cycle will help determine if the meter is being cleaned thoroughly by the purge.

**Regular cleaning cycles** with solvent or DI water may be necessary to effect color changes or to prevent some coatings from depositing on critical internal parts. Designing and maintaining a flush procedure which keeps the meter internals clean & wet is critical to optimum performance & minimum maintenance. Cleaning cycles will vary due to differences in coatings, equipment & cleaning fluids used and some testing may be prudent to determine the most efficient method. Cleaning cycles using D/I water only may require more flushing than those using additives due to the superior cutting ability of solvents. If bells or small orifices restrict adequate purge through the meter, an auxiliary dump valve of ¼" or 3/8" may be installed after the meter to maximize thru-flow.

Full flow meter breakdown instructions are included in the **Maintenance Guide.**

When a meter is removed from the line during maintenance, paint should not be allowed to dry inside. The internals should be cleaned immediately, lubricated and the fluid ports capped. Clean the carbide surfaces at the point where the gear rotates on the shaft. Paint build up here may occur as a thin smear and be difficult to see but will cause friction and accelerate additional paint build up later when the gears are reinstalled. Spin the gears by hand to verify free and easy rotation of gear on shaft and apply a suitable lubrication fluid before closing the meter. After tightening the bolts, a short squirt of shop air will briefly spin the gears which should be easily audible. When re-installing the sensor, turn it in lightly only to a hand tight torque. Do not use a wrench on the pickup as over tightening may cause damage.

**In the event of plugging,** the meter will pass a reduced volume of fluid with an increased back pressure and no frequency output. Care during installation is important as this is the most likely time that contaminants such as tape or metal shavings can enter the meter. Filters should be in line to prevent oversize particles from entering the flow meter.

In the event the meter needs to be returned to the factory for further evaluation flush the meter in place and cap the ports.

## Typical Automated Cleaning Cycle

At the beginning of the cleaning cycle, clean with DI water for a significant period of time before introducing any air at all into the system - for example the first thing the meter should see after push out is a relatively long blast of solvent or DI water for at least 3 seconds or more depending on the coating.

In the middle of the cleaning cycle, short (0.5 sec) air blasts will maximize the scrubbing effect.

At the end of the cleaning cycle, finish with solvent or DI water instead of air. The intention is to put enough purge fluid into the system at this time to have the meter soaking in clean flush fluid at the end of the cycle. When there are gaps in the line or when line stops occur after a color change following this procedure will keep the meter from potentially freezing up. **In general, the meter should never see air for more than a few seconds and should never be run dry.** Note: If new paint and purge fluid mixing is a problem the fill cycle can start with a short 1 second shot of air to separate the purge fluid and the paint.

Fig 2

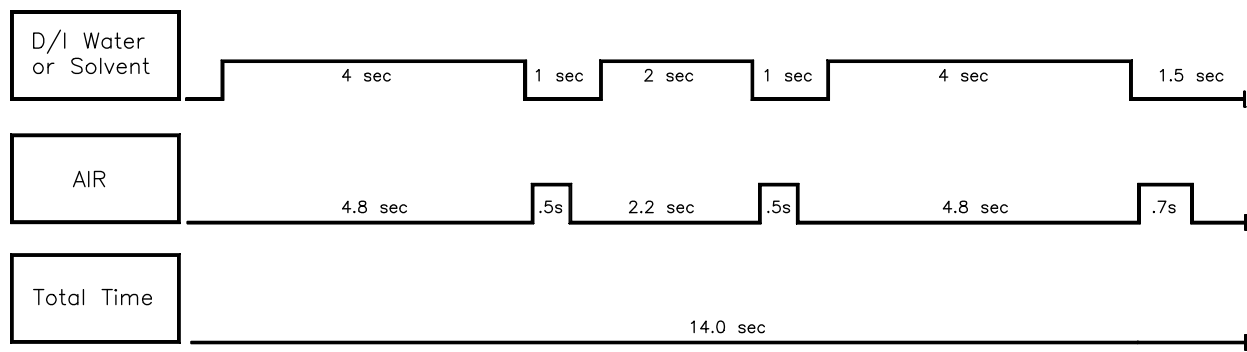

**During line shutdowns such as overnight and over weekends meters should be flushed and left filled with solvent, under pressure, to allow any residue that may have built up to soak and dissolve.**

Filtration is recommended to prevent contaminants from entering the meter. Should the meter become plugged a reduced flow will still be observed from the nozzle or outlet as fluid pressure will squeeze fluid through the meter. Should this occur review the cleaning & maintenance procedures in the following sections.

## Flow Meter Guidelines for Paint Operations

- DO:** Leave flushing solvent in the lines overnight or during extended off -times.  
This keeps internals wet, preventing residual paint from drying, helping start ups.
- DO:** Follow the Maintenance Guide instructions when opening and cleaning a meter.  
During cleaning separate the gears from the shafts. On carbide bearings, clean inside the center of the gear bearing and on the outer surface of the shafts at the point where the gear rotates on the shaft. Apply a suitable lubricating fluid before closing the meter. After tightening the bolts, a short squirt of shop air will briefly spin the gears which should be easily audible.
- DO:** Install and maintain filters.  
The recommended filter should be installed to eliminate potential plugging. Should plugging occur, the meter will still pass fluid but with no signal output.
- DO:** Check electrical compatibility between the meter's output signal and the input of the PLC.  
If signals are not being detected at start up, first check wiring and electrical compatibility.
- DO:** Verify reliable grounding of electrical parts, as per installation guidelines, and a dedicated power supply is recommended.  
Voltage spikes on shared power lines, negligent grounding and sloppy wiring will likely produce erratic readings and chronic maintenance  
  
The control valve will provide back pressure which is beneficial to stable flow control.
- DO:** Install the meter immediately upstream of the regulator or control valve.  
The control valve provides back pressure which stabilizes the flow.
- DON'T** Allow air into the flow meter.  
Always keep the meter internally wet.
- DON'T** Dry paint lines using pressurized air.  
Flow meters are designed to flow liquids. Meters should be closed to air except when air is part of an automated purge cycle. Do not dry lines after purging.
- DON'T** Allow materials to dry inside the meter.  
When a meter is removed from the line during maintenance the internals should be cleaned immediately, lubricated and the fluid ports capped
- DON'T** Over tighten the pickup sensor beyond hand tight  
When installing the pickup sensor turn it in lightly to a hand tight torque. Do not use a wrench on the pickup as over tightening may cause a dimple of metal under the sensor nose to protrude into the gear cavity & interfere with the gear's rotation.
- DON'T** Use water or solvent for calibration or test purposes.  
Water or solvent may not turn the gears at low flow and may leave the impression that the meter is not functioning. A calibration factor (k-factor) is issued with the flow meter which is valid for most fluids except water or equivalent viscosities.

## Calibrations

Each flow meter is calibrated and given a 'K Factor' using a standard calibrating fluid at the factory. This number is accurate for all fluids, with most viscosities, except the most water-like. There should be no need to change this except for the very lowest viscosities close to 1.0 cP.

### If flow readings are too high

If the display shows significantly more than the volume actually dispensed or shows flow when there is definitely no flow - this most likely indicates an electrical noise problem. In such cases turn off nearby motors or heaters or relays, check cable shielding and establish a clean ground independent of other electrical devices before repeating accuracy tests. If the problem continues it may be necessary to relocate the offending device

### If flow readings are too low

If the display shows significantly less than the volume actually dispensed then most likely the meter has a high slippage factor and the fluid is by-passing the gears and the k-factor may require adjustment.

### If it is necessary to adjust the existing k-factor:

Trigger at least 500ml of your sample fluid, in a steady stream, at approximately the desired flow rate, into a graduated beaker. Compare the volume in the beaker to the volume on the display. Do not time the operation merely measure the volume dispensed. Repeat the sample 3 times and take an average. If the result is outside an acceptable margin, adjust the K Factor by the % difference between the average beaker sample and the average displayed total. If the error is not corrected clean the meter thoroughly and repeat the procedure. **Do not use water for this test.**

### If it is necessary to re-calculate a new k-factor:

You will first need a data collecting instrument to count pulses produced by the meter. An AW display may be used in totalizer mode provided the KFT is set to count each pulse (KFT = 10000). Trigger at least 500ml of your sample fluid, in a steady stream, at approximately the desired flow rate, into a graduated beaker. Divide the number of pulses by the volume dispensed and the result is your new k-factor in the units of your sample...in the example above the k-factor units would be impulses/ml.

## Trouble Shooting Guide

TROUBLE	POSSIBLE CAUSE	SOLUTION
Meter indicates lower than actual	Viscosity of fluid is <30cst.	Decrease the K-factor by percent error.
	Excessive pressure differential across meter causing gears to bind.	Reduce flow rate, reduce fluid viscosity.
	Debris in measuring chamber.	Clean meter, change or add filter.
	Upper housing has dimple from over tightening sensor.	Replace upper housing.
Meter indicates higher than actual.	Air in lines.	Add air eliminator.
	Electro-magnetic interference.	Ground flow meter and all electronics.
	Reverse fluid flow.	Add check valve.
Indicator shows flow when there is no flow.	Fluid oscillates.	Check pump, add check valve, increase back pressure.
	Electro-magnetic interference.	Ground flow meter and all electronics. Use shielded cable and relocate away from electrical noise.
No flow indication.	No fluid flow.	Check pump.
	Debris in measuring chamber or gears.	Clean meter, change or add filter.
	Sensor not installed properly.	Check sensor is installed to hand tight. Review sensor guide.
	Faulty wiring.	Check sensor connection and readout connection.
	Faulty sensor.	Replace sensor.
	Upper housing has dimple from over-tightening sensor.	Replace upper housing.
Erratic system indication.	Ground loop in shielding.	Ground shield one place only. Re-route cables from electrical noise.
	Pulsating fluid flow.	Add pulse dampener.

## Limited Warranty

**AW-Lake Company** warrants the product to be in good working order for a period of 1 (one) year from the date of purchase from **AW-Lake Company** or an Authorized **AW-Lake Company** distributor. Should the product fail to be good working order at any time during this 1 year warranty period, **AW- Lake Company** will, at its option, repair or replace the product at no additional charge except as set forth below. Repair parts and replacement products will be furnished on an exchange basis and will be reconditioned or new. All replaced parts and products become the property of **AW- Lake Company**. This limited warranty does not include service to repair damage to the product resulting from accident, disaster, abuse, or a **Non-AW- Lake Company** modification to the product.

Limited Warranty service may be obtained by delivering the product during the 1 year warranty period to **AW-Company** and provide proof of purchase date. If this product is delivered by mail, you agree to insure the product or assume the risk of loss or damage in transit, to prepay shipping charges to warranty location and use the original shipping container or equivalent.

For further information contact:     **AW- Lake Company**  
  **8809 Industrial Drive**  
  **Franksville, WI 53126**  
  **Phone: (262) 884-9800**  
  **Fax:     (262) 884-9810**

**ALL EXPRESS AND IMPLIED WARRANTIES FOR THIS PRODUCT INCLUDING THE WARRANTIES OF MERCHANTABILITY AND FITNESS FOR A PARTICULAR PURPOSE, ARE LIMITED IN DURATION TO A PERIOD OF 1 (ONE) YEAR FROM DATE OF PURCHASE, AND NO WARRANTIES, WHETHER EXPRESS OR IMPLIED, WILL APPLY AFTER THIS PERIOD. SOME STATES DO NOT ALLOW LIMITATIONS ON HOW LONG AN IMPLIED WARRANTY LASTS, SO THE ABOVE LIMITATIONS MAY NOT APPLY TO YOU.**

**IF THIS PRODUCT IS NOT IN GOOD WORKING ORDER AS WARRANTED ABOVE, YOUR SOLE REMEDY SHALL BE REPAIR OR REPLACEMENT AS PROVIDED ABOVE. IN NO EVENT WILL AW COMPANY BE LIABLE TO YOU FOR ANY DAMAGES, INCLUDING ANY LOST PROFITS, LOST SAVINGS OR INCIDENTAL OR CONSEQUENTIAL DAMAGE ARISING OUT OF THE USE OR INABILITY TO USE SUCH PRODUCT, EVEN IF AW COMPANY HAS BEEN ADVISED OF THE POSSIBILITY OF SUCH DAMAGES, OR FOR ANY CLAIM BY ANY OTHER PARTY.**

**THIS WARRANTY GIVES YOU SPECIFIC LEGAL RIGHTS, AND YOU MAY ALSO HAVE OTHER RIGHTS WHICH MAY VARY FROM STATE TO STATE.**