

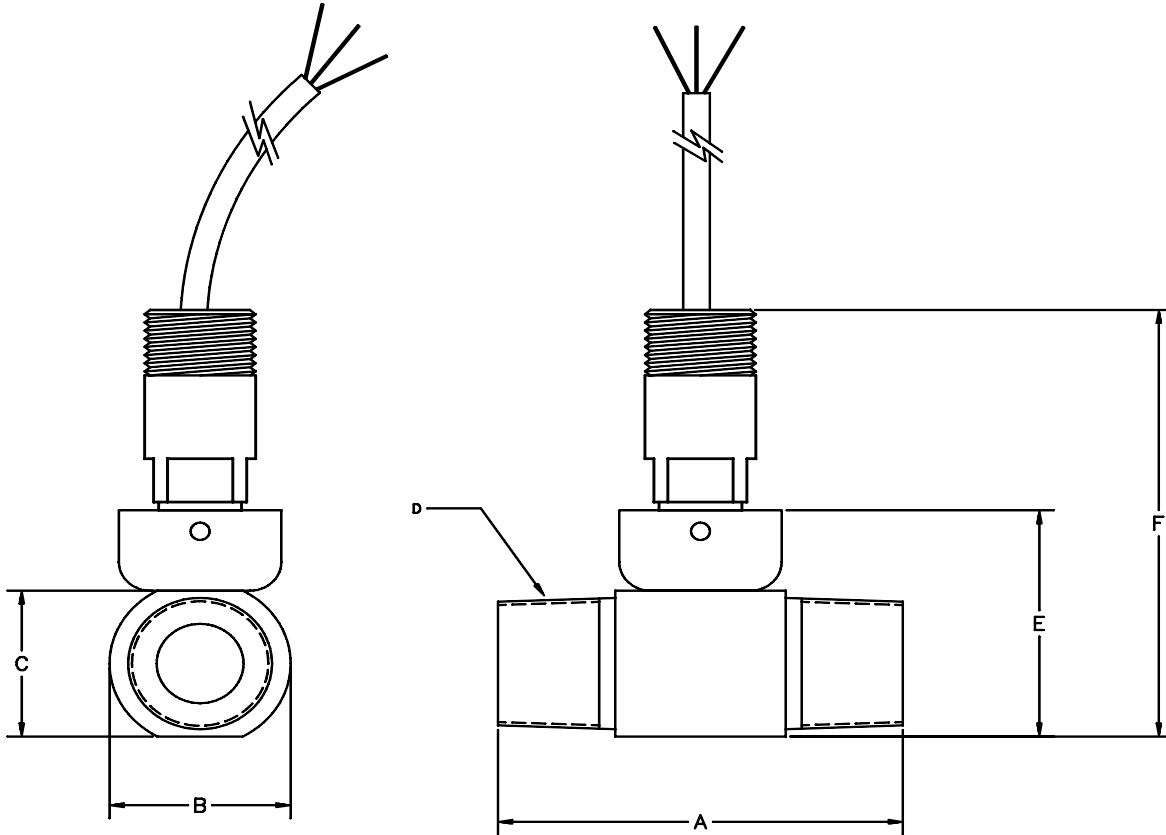

TRG Turbine Dimensions with MAG-P Sensor



Part Number	Dimension in inches					
	A	B	C	D	E	F
TRG-11.250-5	3.00	1.35	1.20	1/2" NPT	2.20	3.85
TRG-11.375-5	3.00	1.35	1.20	1/2" NPT	2.20	3.85
TRG-11.500-5	3.00	1.35	1.20	1/2" NPT	2.25	3.95
TRG-11.750-5	3.00	1.35	1.20	1/2" NPT	2.20	4.00
TRG-11.750	3.00	1.55	1.40	1" NPT	2.45	4.10
TRG-11.875	3.00	1.55	1.40	1" NPT	2.55	4.25
TRG-1110	3.00	2.15	1.95	1-1/2" NPT	3.00	4.60
TRG-1120L	4.00	2.70	2.55	2" NPT	3.60	5.25